

Flow-Tek®

A Subsidiary of BRAY INTERNATIONAL, Inc.

FTG Series Worm Gear Operators For 1/2" - 12" Ball Valves



Flow-Tek's FTG Series Manual Gear Operators were designed to handle the toughest applications and provide years of trouble free service and reliability. The FTG series gear operators feature a ductile iron housing, aluminum bronze gear segment, one piece steel worm gear input shaft with tapered roller bearings on both ends. Adjustable travel stops provide precise adjustment in both open and closed positions. Housings are sealed and weather proof to fully isolate internal parts from atmospheric conditions.

Additionally all models include a corrosion resistant, high visibility valve position indicator.

All models are self-locking and hold any position. All FTG series operators are drilled and tapped to ISO 5211 mounting dimensions.

Output torque is available in range of 5,310 to 70,000 lb-in (600 to 7,900 Nm)

Options

- Locking Device
- Chain Wheels
- Horizontal Flag Indicator
- 2" Square Input Drive Nut
- Grease Fitting
- Flow Pattern Indicators for Multport Valves

FTG SERIES DIMENSIONS AND WEIGHTS - Inches (mm)

Model	Ratio	A	B	D	E	F	H	ISO N	UNC P	Square Q	R Min.	S Min.	h	Radius Max	lbs-in* Nm	lbs kg	øHW
FTG22	22:1	8.9 225	6.5 164	3.9 100	1.7 42.5	5.6 143	3.3 83	F07	5/16 - 18	0.669 17	0.875 22.2	0.06 1.5	1.5 39	0.04 1.0	5,310 600	16 7.2	8 200
FTG30	30:1	13.4 341	10 254	5.6 142	2.5 63	7.7 195	3.5 90	F07 F12	5/16 - 18 1/2 - 13	1.063 27	1.425 36.2	0.09 2.2	1.5 37	0.08 2.0	8,850 1,000	29 13.1	12 300
FTG50	50:1	13.6 346	10 254	7.0 180	3.2 80	8.7 220	4.0 101	F12	1/2 - 13	1.811 46	2.370 60.2	0.11 2.7	1.5 38.5	0.10 2.5	12,391 1,400	39 17.7	12 300
FTG80	80:1	18.5 470	13.5 342	10.0 255	4.7 120	12.2 310	4.7 120	F12 F16	1/2 - 13 3/4 - 10	2.165 55	2.843 72.2	0.17 4.3	2.2 55	0.11 2.8	22,126 2,500	84 38.3	16 400
FTG170	70:1	20.1 553	16.9 428	10.3 260	5.0 126	11.6 296	4.7 120	F-12 F-16	1/2 - 13 3/4 - 10	2.165 55	2.84 72.2	0.17 4.3	2.0 52	0.1 2.8	39,830 4,500	99 45	28 705
FTG190	184:1	23.1 588	17.0 433	12.2 310	5.4 137	13.7 349	5.4 138	F-16	3/4 - 10	2.165** 55	2.843 72.2	0.40 10	2.6 65.5	0.11 2.8	70,000 7,900	139 63	30 762

FTG22 - FTG170

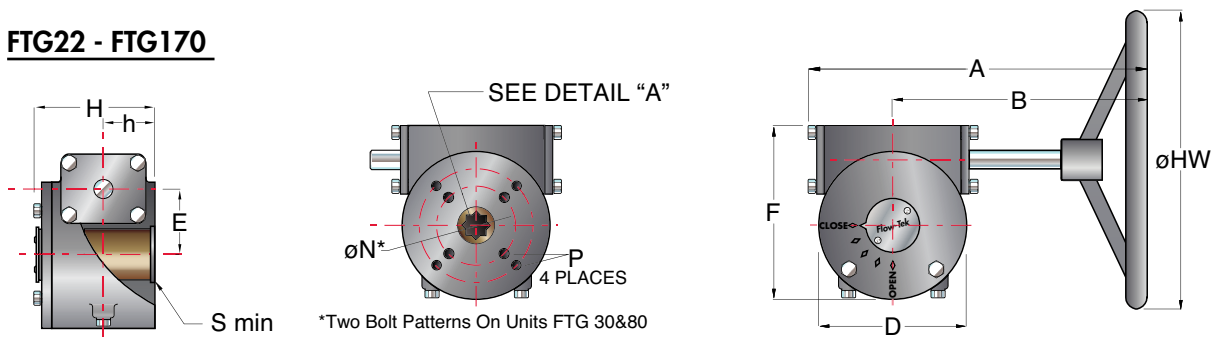

FTG190

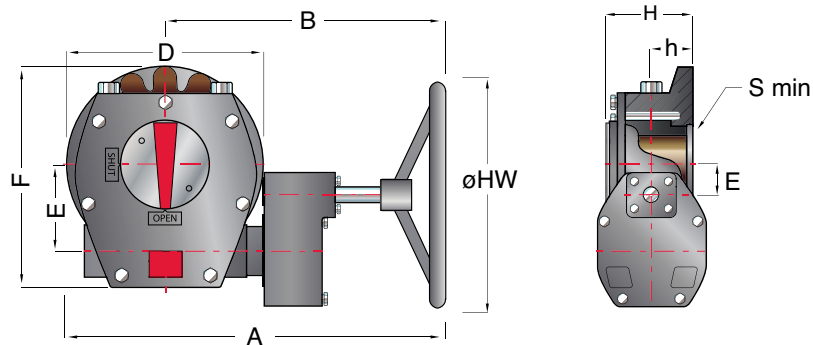

DETAIL "A"

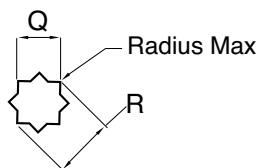

** Optional Round Keyed Connection

3.5" (89mm) Max dia

